

SKA P 100 R507 (COD. E5089M0000)



Island cabinet - ventilated cooler

Technical data

Temperature	0°C +2°C
Voltage and Frequency	230 V~ 50 Hz
Gas	R507
Net dimension	1014 x 1014 x 1014 mm (l x p x h)
Packed dimension	1110 x 1110 x 1140 mm (l x p x h)
Gross capacity	180 l
Net capacity	132 l
Gross weight	130.00 Kg
Net weight	110.00 Kg
Heat insulation	Rigid polyurethane foam "HCFC/CFC/HFC" free
External cabinet	White plasticised steel sheet
Cabinet bottom	Galvanized steel sheet
Kickplate	800 x 864 x 298 mm (w x d x h)
Inner tank	White painted sheet non-toxic + in aluminium on the bottom
Lateral glasses	tempered glass
Bumper	White plastic
Frontal grid - colour	White plasticised steel sheet
Side grid - colour	White plasticised steel sheet
Back grid - colour	White plasticised steel sheet
Compressor	3/8 HP
Condensator	Wire and tube - maintenance free with powered fan
Evaporator	Packed system (finned) with powered fan
Defrosting	Automatic
Climatic class - EN 441	3 (25°C-60%RH)
Plug	European - Angular Plug
Thermometer/Thermostat	Electronic
Brand	FRAMEC
Producer	Mondial Group

SKA P 100 R507 (COD. E5089M0000)



Island cabinet - ventilated cooler

Layout

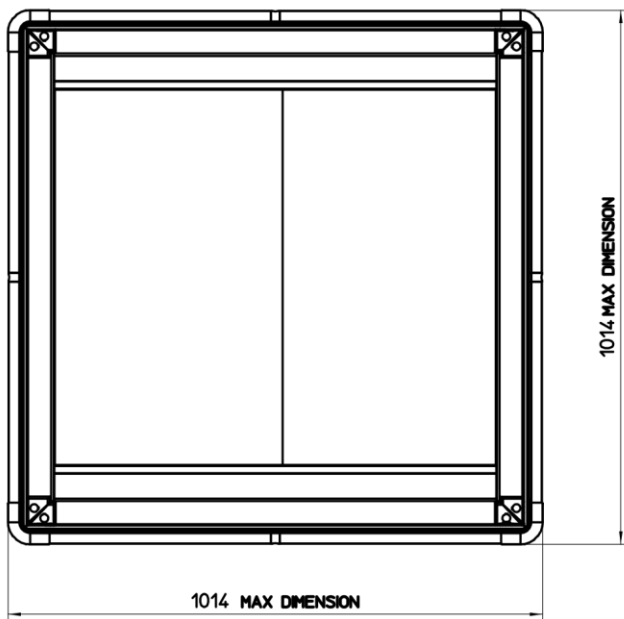
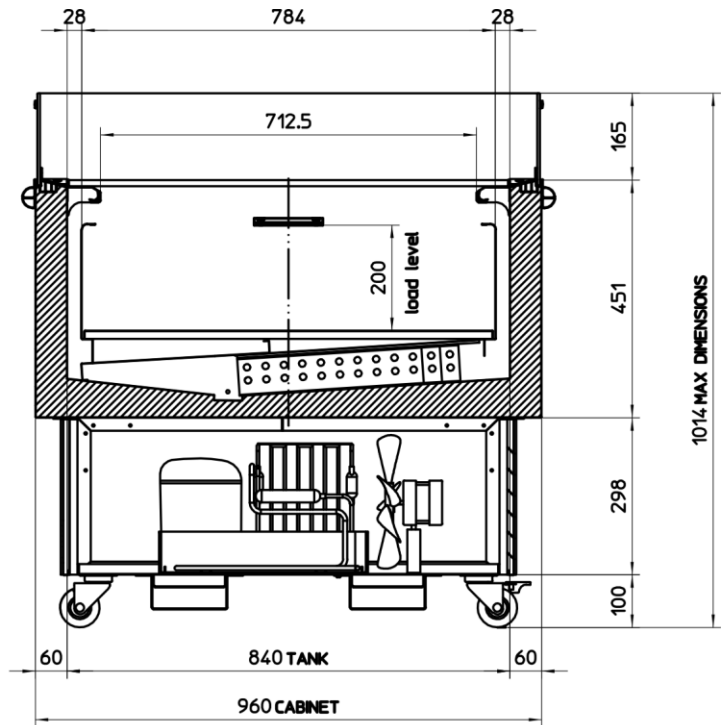
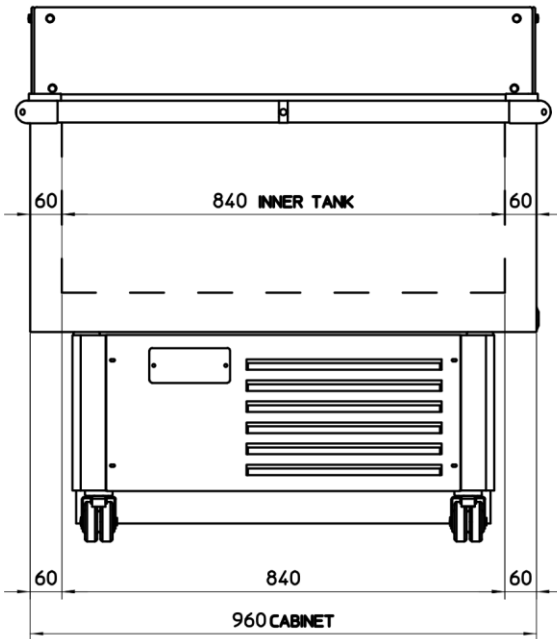

SKA 100

S_46468 - 00

Updated on
29/09/2016